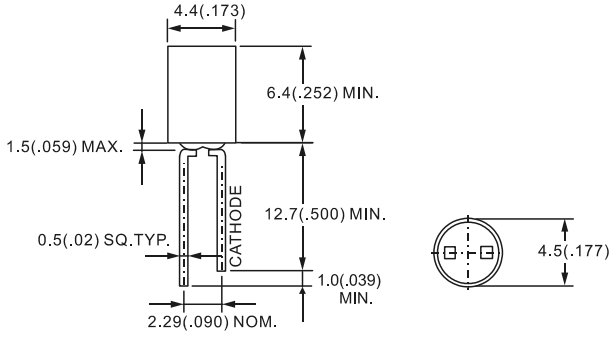
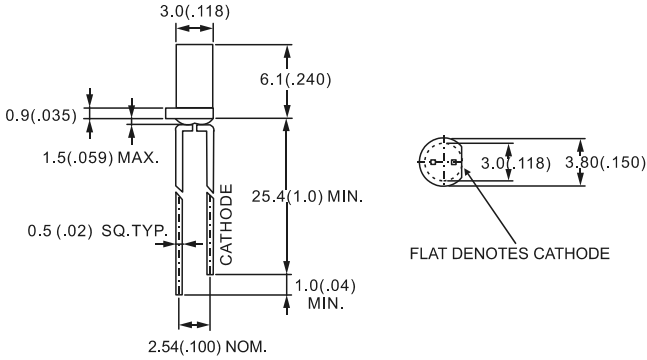
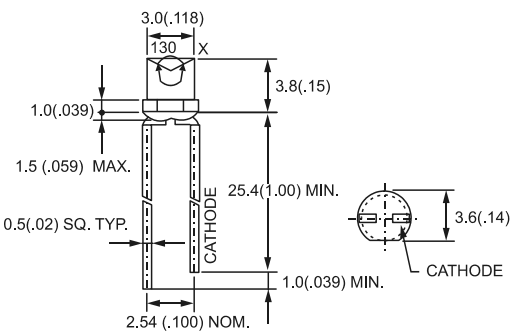
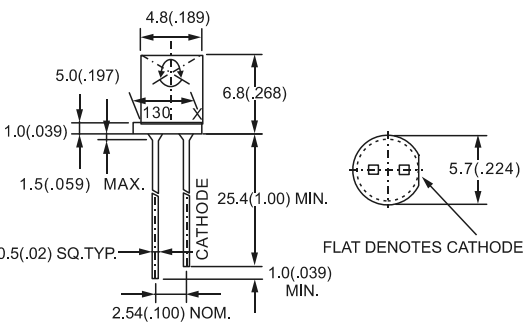
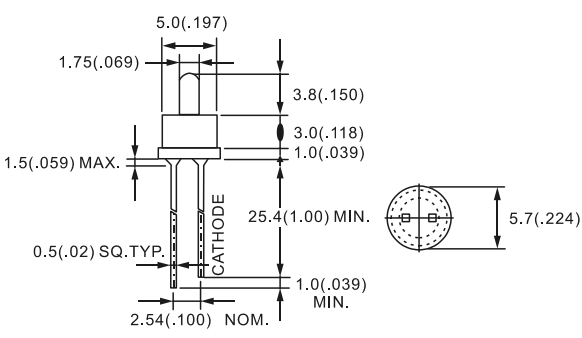

# STANDARD LED LAMPS (RECTANGULAR & CYLINDRICAL TYPES)

Package	Part No.	Chip		Lens Appearance	Absolute Maximum Ratings				Electro-optical Data(At 20mA)			Viewing Angle 2 $\theta$ 1/2 (deg)	Drawing No.
		Material/Emitted Color	Peak Wave Length $\lambda_p$ (nm)		$\Delta\lambda$ (nm)	Pd (mw)	If (mA)	Peak (mA)	Vf (V)		Iv (mcd)		
									Typ	Max	Typ		
Cylindrical 0.5" Lead 4.5 $\phi$	BL-C5121	GaP/GaP/Bright Red	700	Red Diffused	90	40	15	50	2.2	2.6	1.2	150	L-040
	BL-C4521	GaAsP/GaP/Hi-Eff Red	635		45	80	30	150	2.0	2.6	9.0		
	BL-C2121	GaP/GaP/Green	568	Green Diffused	30	80	30	150	2.2	2.6	9.0		
	BL-C3121	GaP/GaP/Hi-Eff Green	585	Yellow Diffused	35	80	30	150	2.1	2.6	8.0		
1.0" Lead Cylindrical $\phi$ 3.0	BL-C5132	GaP/GaP/Bright Red	700	Red Diffused	90	40	15	50	2.2	2.6	3.0	130	L-041
	BL-C4532	GaAsP/GaP/Hi-Eff Red	635		45	80	30	150	2.0	2.6	9.0		
	BL-C2132	GaP/GaP/Green	568	Green Diffused	30	80	30	150	2.2	2.6	9.0		
	BL-CX1132	GaP/GaP/Hi-Eff Green	568		30	80	30	150	2.2	2.6	12.0		
	BL-C3132	GaAsP/GaP/Yellow	585	Yellow Diffused	35	80	30	150	2.1	2.6	8.0		
	BL-C4132	GaAsP/GaP/Orange	635	Orange Diffused	45	100	30	150	2.0	2.6	9.0		
1.0" Lead Cylindrical $\phi$ 3.0	BL-C5435	GaP/GaP/Bright Red	700	Red Trans	90	40	15	50	2.2	2.6	5.0	120	L-042
	BL-C4635	GaAsP/GaP/Hi-Eff Red	635		45	80	30	150	2.0	2.6	15.0		
	BL-C2435	GaP/GaP/Green	568	Green Trans	30	80	30	150	2.2	2.6	15.0		
	BL-CX1435	GaP/GaP/Hi-Eff Green	568		30	80	30	150	2.2	2.6	18.0		
	BL-C3435	GaAsP/GaP/Yellow	585	Yellow Trans	35	80	30	150	2.1	2.6	12.0		
	BL-C4435	GaAsP/GaP/Orange	635	Orange Trans	45	100	30	150	2.0	2.6	15.0		
1.0" Lead Cylindrical $\phi$ 5.0	BL-C5436	GaP/GaP/Bright Red	700	Red Trans	90	40	15	50	2.2	2.6	5.0	120	L-043
	BL-C4636	GaAsP/GaP/Hi-Eff Red	635		45	80	30	150	2.0	2.6	14.0		
	BL-C2436	GaP/GaP/Green	568	Green Trans	30	80	30	150	2.2	2.6	14.0		
	BL-CX1436	GaP/GaP/Hi-Eff Green	568		30	80	30	150	2.2	2.6	16.0		
	BL-C3436	GaAsP/GaP/Yellow	585	Yellow Trans	35	80	30	150	2.1	2.6	13.0		
	BL-C4436	GaAsP/GaP/Orange	635	Orange Trans	45	100	30	150	2.0	2.6	14.0		
Panel Dot 1.0" Lead $\phi$ 1.75	BL-S5131	GaP/GaP/Bright Red	700	Red Diffused	90	40	15	50	2.2	2.6	1.2	75	L-044
	BL-S4531	GaAsP/GaP/Hi-Eff Red	635		45	80	30	150	2.0	2.6	6.0		
	BL-S2131	GaP/GaP/Green	568	Green Diffused	30	80	30	150	2.2	2.6	6.0		
	BL-S3131	GaAsP/GaP/Yellow	585	Yellow Diffused	35	80	30	150	2.1	2.6	4.0		

# STANDARD LED LAMPS (RECTANGULAR & CYLINDRICAL TYPES)

L-040 BL-Cxx21 Series	L-041 BL-Cxx32 Series
 <p>4.4(.173) 6.4(.252) MIN. 1.5(.059) MAX. 0.5(.02) SQ. TYP. 12.7(.500) MIN. 1.0(.039) MIN. 2.29(.090) NOM. 4.5(.177)</p>	 <p>3.0(.118) 6.1(.240) 0.9(.035) 1.5(.059) MAX. 25.4(1.0) MIN. 1.0(.04) MIN. 2.54(.100) NOM. 3.80(.150) FLAT DENOTES CATHODE</p>
L-042 BL-Cxx35 Series	L-043 BL-Cxx36 Series
 <p>3.0(.118) 130 3.8(.15) 1.0(.039) 1.5(.059) MAX. 0.5(.02) SQ. TYP. 25.4(1.00) MIN. 1.0(.039) MIN. 2.54(.100) NOM. 3.6(.14) CATHODE</p>	 <p>4.8(.189) 5.0(.197) 6.8(.268) 1.0(.039) 1.5(.059) MAX. 0.5(.02) SQ. TYP. 25.4(1.00) MIN. 1.0(.039) MIN. 2.54(.100) NOM. 5.7(.224) FLAT DENOTES CATHODE</p>
L-044 BL-Sxx31 Series	
 <p>5.0(.197) 1.75(.069) 3.8(.150) 1.5(.059) MAX. 3.0(.118) 1.0(.039) 25.4(1.00) MIN. 1.0(.039) MIN. 2.54(.100) NOM. 5.7(.224)</p>	

- Notes: 1. All dimensions are in millimeters (inches).  
2. Tolerance is  $\pm 0.25\text{mm}$  (.010")

# STANDARD LED LAMPS (TOWER TYPES)

Package	Part No.	Chip		Lens Appearance	Absolute Maximum Ratings				Electro-optical Data(At 20mA)			Viewing Angle 2θ 1/2 (deg)	Drawing No.
		Material/Emitted Color	Peak Wave Length λ <sub>p</sub> (nm)		Δ λ (nm)	Pd (mw)	If (mA)	Peak (mA)	Vf (V)		Iv (mcd)		
									Typ	Max	Typ		
1.0" Lead Tower φ3.0	BL-S5132	GaP/GaP/Bright Red	700	Red Diffused	90	40	15	50	2.2	2.6	1.2	100	L-045
	BL-S4532	GaAsP/GaP/Hi-Eff Red	635		45	80	30	150	2.0	2.6	6.0		
	BL-S2132	GaP/GaP/Green	568	Green Diffused	30	80	30	150	2.2	2.6	6.0		
	BL-SX1132	GaP/GaP/Hi-Eff Green	568		30	80	30	150	2.2	2.6	9.0		
	BL-S3132	GaAsP/GaP/Yellow	585	Yellow Diffused	35	80	30	150	2.1	2.6	5.0		
	BL-S4132	GaAsP/GaP/Orange	635	Orange Diffused	45	80	30	150	2.0	2.6	6.0		
1.0" Lead Tower φ2.75	BL-S5133	GaP/GaP/Bright Red	700	Red Diffused	90	40	15	50	2.2	2.6	1.4	100	L-046
	BL-S4533	GaAsP/GaP/Hi-Eff Red	635		45	80	30	150	2.0	2.6	6.0		
	BL-S2133	GaP/GaP/Green	568	Green Diffused	30	80	30	150	2.2	2.6	6.0		
	BL-SX1133	GaP/GaP/Hi-Eff Green	568		30	80	30	150	2.2	2.6	9.0		
	BL-S3133	GaAsP/GaP/Yellow	585	Yellow Diffused	35	80	30	150	2.1	2.6	5.0		
	BL-S4133	GaAsP/GaP/Orange	635	Orange Diffused	45	80	30	150	2.0	2.6	6.0		
1.0" Lead Tower φ2.0	BL-S5136	GaP/GaP/Bright Red	700	Red Diffused	90	40	15	50	2.2	2.6	1.2	70	L-047
	BL-S4536	GaAsP/GaP/Hi-Eff Red	635		45	80	30	150	2.0	2.6	7.0		
	BL-S2136	GaP/GaP/Green	568	Green Diffused	30	80	30	150	2.2	2.6	7.0		
	BL-SX1136	GaP/GaP/Hi-Eff Green	568		30	80	30	150	2.2	2.6	10.0		
	BL-S3136	GaAsP/GaP/Yellow	585	Yellow Diffused	35	80	30	150	2.1	2.6	6.0		
	BL-S4136	GaAsP/GaP/Orange	635	Orange Diffused	45	80	30	150	2.0	2.6	7.0		
1.0" Lead Tower φ2.8	BL-S5137	GaP/GaP/Bright Red	700	Red Diffused	90	40	15	50	2.2	2.6	15	100	L-048
	BL-S4537	GaAsP/GaP/Hi-Eff Red	635		45	80	30	150	2.0	2.6	22		
	BL-S2137	GaP/GaP/Green	568	Green Diffused	30	80	30	150	2.2	2.6	22		
	BL-SX1137	GaP/GaP/Hi-Eff Green	568		30	80	30	150	2.2	2.6	25		
	BL-S3137	GaAsP/GaP/Yellow	585	Yellow Diffused	35	80	30	150	2.1	2.6	21		
	BL-S4137	GaAsP/GaP/Orange	635	Orange Diffused	45	80	30	150	2.0	2.6	22		
1.0" Lead Tower φ3.0	BL-S5137A	GaP/GaP/Bright Red	700	Red Diffused	90	40	15	50	2.2	2.6	15	70	L-049
	BL-S4537A	GaAsP/GaP/Hi-Eff Red	635		45	80	30	150	2.0	2.6	22		
	BL-S2137A	GaP/GaP/Green	568	Green Diffused	30	80	30	150	2.2	2.6	22		
	BL-SX1137A	GaAsP/GaP/Hi-Eff Green	568		30	80	30	150	2.2	2.6	25		
	BL-S3137A	GaAsP/GaP/Orange	585	Yellow Diffused	35	80	30	150	2.1	2.6	21		
	BL-S4137A	GaAsP/GaP/Orange	635	Orange Diffused	45	80	30	150	2.0	2.6	22		
1.0" Lead Tower φ1.8	BL-S51L8	GaP/GaP/Bright Red	700	Red Diffused	90	40	15	50	2.2	2.6	1.0	70	L-050
	BL-S45L8	GaAsP/GaP/Hi-Eff Red	635		45	80	30	150	2.0	2.6	5.0		
	BL-S21L8	GaP/GaP/Green	568	Green Diffused	30	80	30	150	2.2	2.6	5.0		
	BL-SX11L8	GaAsP/GaP/Hi-Eff Green	568		30	80	30	150	2.2	2.6	8.0		
	BL-S31L8	GaAsP/GaP/Yellow	585	Yellow Diffused	35	80	30	150	2.1	2.6	4.0		
	BL-S41L8	GaAsP/GaP/Orange	635	Orange Diffused	45	80	30	150	2.0	2.6	5.0		
1.0" Lead Tower φ2.0	BL-S5149	GaP/GaP/Bright Red	700	Red Diffused	90	40	15	50	2.2	2.6	1.0	100	L-051
	BL-S4549	GaAsP/GaP/Hi-Eff Red	635		45	80	30	150	2.0	2.6	8.0		
	BL-S2149	GaP/GaP/Green	568	Green Diffused	30	80	30	150	2.2	2.6	8.0		
	BL-S3149	GaAsP/GaP/Green	568	Yellow Diffused	30	80	30	150	2.2	2.6	7.0		
	BL-S4149	GaAsP/GaP/Orange	635	Orange Diffused	35	80	30	150	2.1	2.6	8.0		
1.0" Lead Tower φ2.0	BL-S5149A	GaP/GaP/Bright Red	700	Red Diffused	90	40	15	50	2.2	2.6	1.0	120	L-052
	BL-S4549A	GaAsP/GaP/Hi-Eff Red	635		45	80	30	150	2.0	2.6	8.0		
	BL-S2149A	GaP/GaP/Green	568	Green Diffused	30	80	30	150	2.2	2.6	8.0		
	BL-S3149A	GaAsP/GaP/Yellow	585	Yellow Diffused	35	80	30	150	2.1	2.6	7.0		

- Remark: 1. Hi-eff Red/Hight-Efficiency Red.  
 2. Trans/Transparent.  
 3. 2θ 1/2 The off-axis angle at which the luminous intensity is half the axial luminous intensity.

# STANDARD LED LAMPS (TOWER TYPES)

<p><b>L-045</b>      <b>BL-Sxx32 Series</b></p>	<p><b>L-046</b>      <b>BL-Sxx33 Series</b></p>
<p><b>L-047</b>      <b>BL-Sxx36 Series</b></p>	<p><b>L-048</b>      <b>BL-Sxx37 Series</b></p>
<p><b>L-049</b>      <b>BL-Sxx37A Series</b></p>	<p><b>L-050</b>      <b>BL-SxxL8 Series</b></p>
<p><b>L-051</b>      <b>BL-Sxx49 Series</b></p>	<p><b>L-052</b>      <b>BL-Sxx49A Series</b></p>

Notes: 1. All dimensions are in millimeters (inches).  
 2. Tolerance is  $\pm 0.25\text{mm}$  (.010")